



Synco™ living

Central apartment unit with **QAX913** consumption data acquisition

Series A

-
- Heating and cooling control management for an apartment including pre-control for 2 room groups
 - Ventilation plant management
 - Air conditioning management (e.g. split units)
 - Selection of operating mode, timer and holidays / special day function for the apartment
 - Independent time switches and operating modes for 12 rooms
 - Absence function (heating, cooling, ventilation, hot water, lights) with presence simulation (light)
 - Window, door as well as water and smoke detector monitoring
 - Summer operation with preselected valve position for cooling mode
 - Display of meteorological data
 - DHW heating with time switch and selection of operating mode
 - Wireless communication with the devices of the Synco living, and Hager tebis TX RF product ranges.
 - Operation and control of lights and blinds and scenes via 4 pairs of universal buttons, time switch and events
 - Universal input and output
 - Remote control via handheld control unit or via web server
 - Records consumption data for heat, water, electricity and gas
 - KNX-based wireless (868 MHz, bidirectional) and wired data transmission
 - Mains-powered AC 230 V.

- Heating and cooling control management for an apartment.
- Radiator / floor cooling monitored for dew point.
- Increase of the Economy room setpoint and minimum flow temperature setpoint dependent on composite outside air temperature.
- Collects heating / refrigeration requests from individual rooms.
- Generates heating or refrigeration request signals and transmits them to heat and refrigeration generation via wired bus, via heat / refrigeration demand relays or via DC 0...10 V output to the RRV912 or RRV934.
- Suited for heating and cooling plants with central distribution (e.g. floor heating) and radiators with decentralized connections.
- Limits the heating setpoint (max.) and cooling setpoint (min.).
- RRV912 / RRV918 heating controllers control the heating circuit controllers and SSA955 radiator control actuators.
- Flow temperature control of 2 independent room groups with limitation function (min. / max.) and maintain return temperature high / low.
- Room group pump control via universal relay outputs.
- Hot water pump / diverting valve control via universal relay output; record hot water temperature via a universal input.
- Ventilation plant management via multi-controller RRV934.
- Night cooling function (heat recovery bypass function).
- Air conditioning control (split units) via the universal outputs (local and RRV91x) or via S-mode (KNX TP).
- Release of cooling enable for each room dependent on the composite outside air temperature, present HVAC level, window status and a heating demand.
- Monitors door and window switches and smoke detectors.
- Monitors water, CO₂ and gas detectors.
- Shut off elements lock water and natural gas lines.
- Operation of lights and blinds via softkey, time switch and events.
- Presence simulation using random switch on and off, combined with continuous ON of one or more light sources.
- Generate, store and retrieve scenes.
- Display outside temperature curve and outside air pressure over the last 24 hours using the QAC910 meteo sensor.
- Displays open windows and doors.
- Displays weather trends (sunny, variable, rainy).
- Records consumption data for heat, water, electricity and gas using the consumption data interface WRI982.
- Remote access via Siemens OZW77x central communication units.
- Smart phone app or web portal remote control of the Synco living system.

Equipment combinations

The central apartment unit can be used together with the following wireless products of the Siemens Synco living system and those of other suppliers of KNX RF products:

Device description	Product no.	Documentation *)
Type of room unit	QAW910	N2703en
Room temperature sensor	QAA910	N2701en
Meteo sensor	QAC910	N2702en
Heating circuit controller	RRV912	N2705en
Heating circuit controller	RRV918	N2706en
Multi-controller	RRV934	N2709de
Radiator control actuator	SSA955	N2700en
Radio repeater	ERF910	N2704en
Water detector	QFP910	N2732en
Consumption data interface	WRI982	N2735en
Web server	OZW772.xx	N5701
Door and window switches	AP 260/11	GAMMA
Light and blind actuators	tebis TX radio	Hager

The QAX913 central apartment unit can be used together with the following hard wired products from the Siemens Synco 700 system:

Device description	Product no.	Documentation *)
Synco 700 controls	RM..	S3110
Central communication units	OZW771	N3117
Service tool	OCI700.1	N5655
Serviceinterface für USB / KNX	OCI702	A6V10438951

For detailed information, refer to product range overview of Acvatix valves and actuators 0-92205-en.

*) Die Dokumente können unter <http://siemens.com/bt/download> bezogen werden.

Additional KNX TP units can be integrated via S-mode (refer to document CE1Y3110en).

Device description	Product no.	Documentation
Interface for cooling units (split units)	IRSC	ZENNiO

Ordering

Please specify the quantity, product name and type when ordering.

Scope of delivery

QAX913-9: Featuring multi-lingual mounting instructions and the necessary installation materials. The following languages can be set on the QAX913-9: Bulgarian, Danish, German, English, Finnish, French, Greek, Italian, Croatian, Dutch, Norwegian, Polish, Portuguese, Romanian, Russian, Swedish, Serbian, Slovakian, Slovenian, Spanish, Czech, Turkish, and Hungarian.

The instructions/guides can be downloaded from the Internet in the various languages at www.siemens.com/syncoliving-td.

Ordering references

<i>Product no.</i>	<i>Product number</i>	<i>Designation</i>
QAX913-9	S55621-H126	Central apartment unit with mounting instructions

Functions

Main functions

The central apartment unit manages heating, cooling, ventilation and hot water control of an apartment with up to 12 rooms. It also controls air conditioners (split units), lighting and blinds actuating devices and monitors light actuators, door and window switches as well as smoke, CO, natural gas and water detectors.

You can record, together with the consumption data interface WRI982, heating / refrigeration, hot and chilled water, electricity and natural gas, display it on the QAX913 central apartment unit and forward it via the OZW772 web server to a service provider.

The QAX913 also serves as an operator and display unit for the apartment.

Specific functions for heating and cooling plants

Heating and cooling request

The central apartment unit forms a heat or cooling demand signal from the collected heating or cooling requests and forwards it to the heat or refrigeration generation controller.

The heat / refrigeration demand signal can be delivered via the universal relay output (switching) or at the DC 0...10 V output (modulating) of an RRV912 heating circuit controller or RRV934 multi-controller.

Flow temperature control / limitation

The flow temperature can be controlled via the RRV934 multi-controller. It is regulated with the help of the heat / refrigeration demand signal. Minimum as well as maximum limitation of the flow temperature setpoint can be provided, based on an adjustable value. If the temperature request is invalid, flow temperature regulation becomes inactive and the control elements are closed during Winter operation (no output). The central apartment unit supports two room groups (e.g. floor heating / cooling and radiators) that may be controlled independently.

Limitation of the return temperature

The return temperature can be maintained at a high or low level, based on an adjustable value. This prevents, for example, water that is too hot from returning to heat generation. Return temperature limitation is given priority over flow temperature limitation. Return temperature limitation acts on the mixing valve for the room group.

Setpoint limitation

Setpoint limitation limits the heating setpoint to a maximum value and the cooling setpoint to a minimum value for the entire apartment.

Room unit / Room temperature sensor

The central apartment unit calculates the mean value and uses it for room temperature control if a room unit and one or 2 room sensors are assigned to a room.

Parallel operation of heating circuit controllers

Several heating circuits connected to an RRV912 / RRV918 heating circuit controller can be combined to one room and operated in parallel. In that case, the first channel ensures the actual room control and, at the same time, controls the other assigned channels.

Parallel operation of radiator control actuators	Up to 6 SSA955 radiator control actuators can be combined to one room and operated in parallel. The first radiator control actuator (master controller) assumes actual room control plus wireless control of the other assigned radiator control actuators (parallel controllers).
Zone control	Multiple heating circuits connected to common heat distribution can be controlled jointly as a zone. The zone valve (3-point) is controlled based on the temperature measured value from the room unit and / or room temperature sensor installed in the reference room.
Room group pumps	The central apartment unit issues the enable for room group pumps. They can be either connected to the internal relay output or a relay output of one of the RRV912 / RRV918 heating circuit controllers or RRV934 multi-controller.
Antilime function	The QAX913 can trigger an antilime function at regular intervals to prevent valve plugs and pump impellers from seizing during longer off periods. The function ensures that the valve actuators extend to the fully open and then to the fully closed position and that the pumps are activated for short periods of time (valve kick). Frequency and the time of day the function is performed can be adjusted. The anti-lime function acts either locally or on plant components connected to the RRV912 / RRV918 heating circuit controller and also on the wireless SSA955 radiator control actuators.
Outside air temperature-controlled night set point	The room temperature setpoint in Economy mode to heat all rooms is increased dependent on the composite outside temperature. The transitions are adjustable to prevent peak loads during changeover, for example, from Economy to Precomfort or Comfort.
Minimum flow setpoint	The minimum flow temperature setpoint is raised depending on the composite outside air temperature, ensuring a minimum flow temperature in uncontrolled rooms.
Summer operation	The central apartment unit triggers summer operation. Changeover may occur manually, by date, as per attenuated outside air temperature, via a digital input, or through active changeover to cooling mode. The heating circuit valves connected to an RRV912 / RRV918 heating circuit controller have a position of 0% or 100% and the SSA955 radiator control actuators are driven to the preselected valve positions.
DHW charging / DHW control	The QAX913 provides hot water control with the help of a specific hot water time switch. Hot water is enabled or locked by on the QAX913 or a hot water sensor connected to a RRV912 / RRV918 / RRV934. The signal for DHW charging, or changeover, is delivered either via the internal relay output or the relay output of an RRV912 / RRV918 heating circuit controller or the multi-controller RRV934. DHW charging can take place via diverting valve / charging pump and / or an electric immersion heater.
Specific functions for floor cooling	
Room temperature control	4 cooling setpoints can be preset for each room. A flow refrigeration request is calculated per room group for primary processing. The room group controller RRV934 controls the flow temperature depending on the composite outside air temperature and individually adjustable cooling curve. QAX913 can override room controllers RRV912, RRV918 and SSA955 in cooling mode.

Dew point monitoring A condensation monitor (QXA2000, AQX2000) monitors the dew point on the flow pipe.
The condensation monitor acts simultaneously on both room groups (1 dew point monitor per QAX913).

Floor cooling enable Floor cooling is enabled:

- Manually on the QAX913.
- Via external switch (digital).
- Via programmable date.
- Via composite outside air temperature.
- Via KNX S-mode.

Specific functions for ventilation and air conditioning units

Ventilation The QAX913 can control a ventilation plant with up to 3 ventilation stages via multi-controller RRV934. The stages can be controlled manually, via a weekly scheduler or using an air quality or humidity sensor. Ventilation may be influenced by absences, holiday functions or an open window.

The following operating and control functions are available:

- The apartment time activates apartment operating mode "Comfort" for an adjustable period.
- Forced ventilation activates the maximum ventilation stage for a predefined period.
- Cooler outside air flows through the heat recovery bypass during Summer mode as part of active night cooling.
- Counts operating hours to generate a maintenance message.
- Enable kitchen fume hoods via an open window to ensure replacement air.
- Displays active chimney ventilation mode (external plant).

Cooling enable contact 1 cooling enable contact can be assigned to each room to activate cooling unit (e.g. split unit).

The enable can occur via the local relay contact for the central apartment units, the relay contacts to the heating circuit controller RRV912 / RRV918, the multi-controller RRV934 or via S-mode.

Air condition via ZENNiO module Integration of the ZENNiO Interface (S-mode TP) allows the central apartment unit to control the operating mode, setpoint and enable for the air conditioner (e.g. split unit) per room. It can support heating and cooling mode for the air conditioning unit.

The room temperature control is autonomously assumed by the air conditioning unit.

Specific monitoring and operating function

Door and window switches

The central apartment unit monitors the connected door and window switches. A monitor delay can be parameterized on door and window switches as well as a detector delay for door switches. Setting the monitor delay to infinity only re-enables monitoring after the doors are closed. Windows and doors that are opened when monitoring is enabled are automatically excluded from monitoring. The opening of a monitored door / window switch can be used for triggering a switching group (event-driven) and to generate an alarm. The door and window switches are also used for the window airing function. As soon as a window monitored by a window switch is opened, the heating circuits for the respective room stop opening their valves, even if the room temperature drops for short periods. The room temperature level drops to protection mode after a set period expires, until the window is closed again. The "normal" control mode is resumed after the window is closed. An open window can also influence operation of a ventilation plant or air conditioner. This prevents unnecessary heat losses during the airing phase and subsequent overheating. Exhaust hoods can also be influenced by monitoring window switches.

Smoke detector

The central apartment unit monitors the connected smoke detectors (S-Mode TP).. A responding smoke detector can trigger a switching group (event-driven) and triggers an alarm in any case.

Water detector

The central apartment unit monitors connected water detectors. A responding water detector can be used to enable a water shutoff valve and an interior siren and triggers an alarm in any case.

CO or gas detector

The central apartment unit monitors connected CO or gas detectors. A responding CO / gas detector can be used to enable a natural gas shutoff valve and an interior siren and triggers an alarm in any case.

Weather station

The central apartment unit receives measured values for outside air pressure and air pressure from the meteo sensor or via KNX-TP. The current measured values for outside air pressure and outside temperature, as well as the air pressure trend, can be displayed in the quiescent picture. The quiescent picture displays changes in outside air pressure over the last few hours in the form of an arrow. Moreover, the weather trend (sunny, variable, rainy) is determined based on a change in air pressure and the absolute pressure, and is displayed in the quiescent picture. The curve for outside air temperature and outside air pressure over the last 24 hours can be queried via 2 info pages.

Lighting control

The central apartment unit or external switches (transmitters) can be used to switch or dim every connected light fixture. In addition to manual operation, the light settings can be made via the internal time switch (the time switch can be processed "always" or "for absences only"), presence simulation, scenes or events (e.g. twilight, absence). Suitable are Siemens GAMMA and Hager tebis KNX RF lighting actuators, as well as KNX TP lighting actuators from other manufacturers..

Blind control

The central apartment unit or external switches (transmitters) can be used to adjust blinds in steps, or to fully open or close them by a press of a button.

In addition to the manual adjustment of blinds, the blinds settings can be made via the internal time switch (the time switch can be processed "always" or "for absences only"), presence simulation, scenes or events (e.g. twilight, absence).

Suitable are Siemens GAMMA and Hager tebis blind actuators, as well as KNX TP blind actuators from other manufacturers.

Scenes

The different blind positions (fully open or fully closed) and different light settings (on, off, dimming state) can be saved as scenes and retrieved later on.

In addition to manual queries of scenes, a scene may also be activated via the internal time switch (the time switch can be processed "always" or "for absences only"), presence simulation, scenes or events (e.g. twilight, absence).

Smart phone app

Whether at home or on the go – the HomeControl app, in combination with the OZW772 web server, provides intuitive and simple control of your heating, air conditioning and ventilation system, as well as light and shading, from anywhere.

Specific functions to acquire and display consumption data

Consumption data acquisition

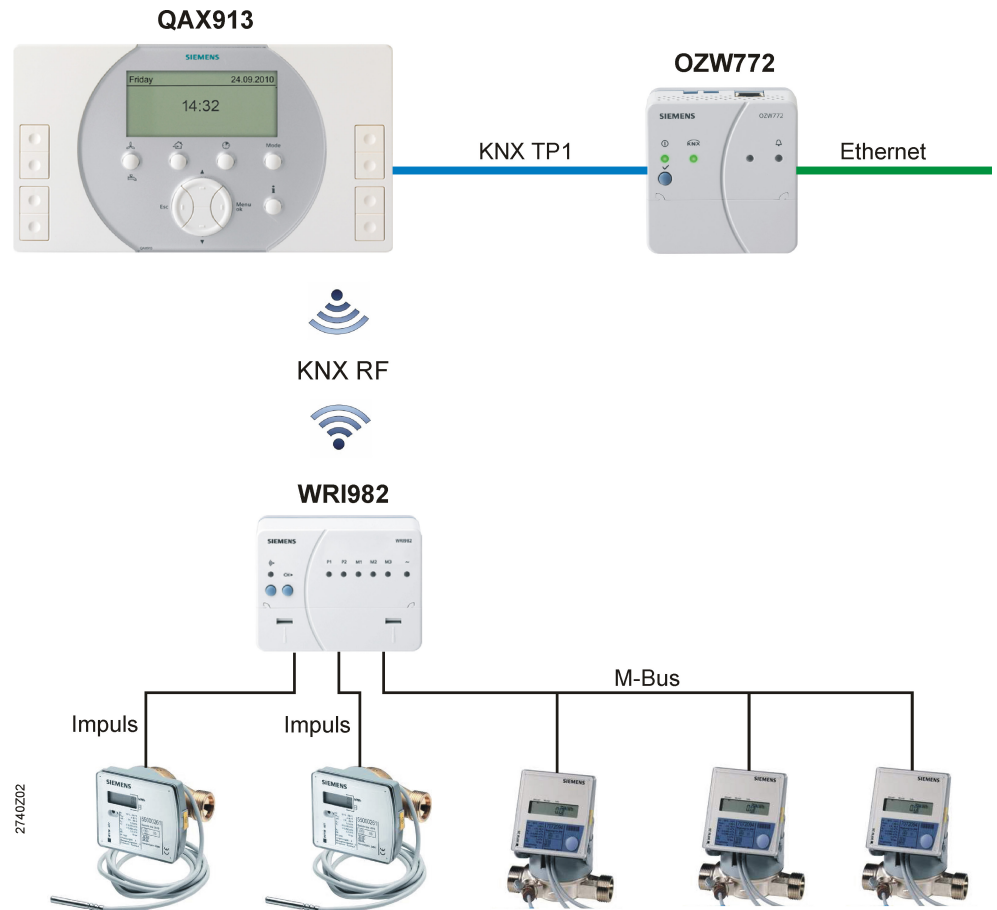

Integrate the consumption data interface WRI982 to display energy consumption on the central apartment unit and send it to a service provider via web server OZW772.

Monthly and annual cutoff values are displayed and forwarded in addition to current meter readings. A corresponding info page is maintained for each meter type.

Available meter types and max. number

2 pulse and 3 M-bus meters can be connected to one WRI982 (a total of up to 5 meters).

What types and number of meters can be learned by a QAX913 central apartment unit?

4 heat and / or cold meters

4 chilled water meters

4 hot water meters

3 electricity meters

3 gas meters

2 other meters (e.g. for steam or oil)

Synergyr integration

The Synco living ECA system is fully compatible with the Synergyr system and permits a conversion of individual units into a Synergyr system (partial migration). The meter information is displayed on the QAX913 central apartment unit and moreover forwarded via the Synergyr building bus to the OZW30 building central station.

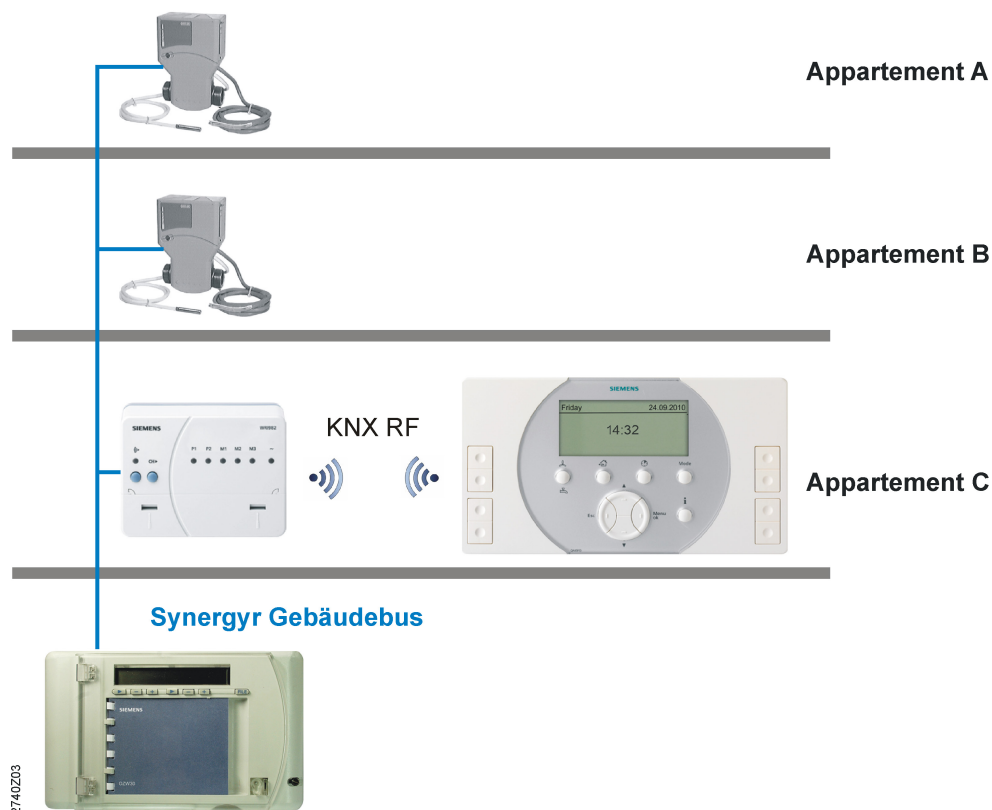

Detailed information the Synco living ECA System is available in the datasheet on the consumption data interface (N2735en).

Device and system functions

Inputs and outputs

Synco living features a number of inputs and outputs which can be used either via the universal input / universal output of the central apartment unit (locally) or the universal inputs / universal outputs of the RRV912 / RRV918 heating circuit controllers or the RRV934 multicontroller.

The inputs and outputs can be assigned the following functions:

Inputs

- Changeover of operating mode (apartment operating mode and / or hot water operating mode)
- Changeover to summer operation
- Cooling enable
- Heating / cooling changeover
- Changeover of monitoring function
- Dew point monitor
- Flow and return sensor
- Ventilation switch 1 and 2 (e.g. Hygrostat)
- Chimney mode
- Triggering the absence function
- Twilight function (e.g. by means of a twilight switch) for triggering a switching group or for enabling presence simulation)
- Fault inputs 1 – 8

- DHW sensor
- Air quality sensor (CO₂ sensor)
- Humidity sensor

Outputs

- Transmits heat demand (switching)
- Transmits heat demand DC 0...10 V
- Transmits cooling demand (switching)
- Transmits cooling demand DC 0...10 V
- Cooling enable
- Switching room group pump 1 - 2
- Precontroller mixing valve 1 - 2
- Step switch 1 to 3 stages
- Heat recovery bypass
- Enable exhaust hood
- Enable cooling unit 1 - 12
- Transmits changeover to summer operation
- Status output (on / off) for reporting definable events
- Window / door state output (on / off) for signaling open windows and doors
- DHW charging pump / DHW diverting valve
- Electric immersion heater
- Switching group relays 1 – 8
- Fault outputs 1 - 2
- Monitoring state
- Status outputs 1 - 4
- Water shutoff valve
- Gas shutoff valve

Fault inputs / outputs

The central apartment unit has 8 fault inputs and 2 fault outputs which can be used either via the universal input / universal output on the QAX913 (locally) or the universal inputs / universal outputs on the RRV912 / RRV918 heating circuit controllers or the RRV934 multicontroller.

Faults of external system components, such as a faulty oil tank level switch, can be transmitted to the central apartment unit via 8 fault inputs. Each fault input can be assigned one of the following fault types:

- Water leak
- Gas leak
- CO alarm
- Panic
- Emergency
- Fault 1 - 3

System-internal faults can be transmitted via fault outputs to external components.

Communication

The central apartment unit is capable of communicating via a wireless bus (KNX RF) or a wire-bound bus (KNX TP).

Service interface

The OCI700 service tool or the OCI702 service interface can be connected to the service interface (RJ45) located on the underside of the central apartment unit.

Establishing the wireless connection	<p>The individual wireless components are connected to the central apartment unit by selecting the room / switching group / function to be assigned to the new wireless components and then pressing the connect or function button for the corresponding components.</p> <p>When connecting devices from the Hager tebis RF range, the TX100 configurator is required (supplied by Hager).</p>
Displaying wireless connections	<p>To check the connections made, a list with all devices can be displayed for each room. In addition, device lists with smoke detectors, meteo sensors, switching group relays and fault inputs and outputs are available.</p>
RF binding test	<p>Using the binding or multifunction buttons, a connection test can be triggered on the individual devices. The central apartment unit indicates error-free connections both optically and audibly.</p>
Monitoring devices	<p>The connected RF devices are monitored on a regular basis. An error message is displayed on the central apartment unit when no signal is found.</p>
RF failure	<p>Control is no longer guaranteed if radio communications between the central apartment unit and the system components to be controlled are interrupted. If communication breaks down, the position of the actuators connected to an RRV934 multi-controller is maintained and can only be changed manually. The heating circuit valves on RRV912 and RRV918 will open. By making use of the built-in room temperature sensor, the SSA955 radiator control valves continue to provide control, maintaining a room temperature setpoint of 21 °C.</p> <p>Ventilation plants continue to operate at the present ventilation state for about 30 minutes and then shut down.</p> <p>System components resume normal control operation as soon as radio communications are reestablished.</p>
Mains failure	<p>Control is no longer secure in the event of a power failure to the central apartment unit.</p> <p>If communication breaks down, the position of the actuators connected to an RRV934 multi-controller is maintained and can only be changed manually. The heating circuit valves on RRV912 and RRV918 will open. By making use of the built-in room temperature sensor, the SSA955 radiator control valves continue to provide control, maintaining a room temperature setpoint of 21 °C.</p> <p>Ventilation plants continue to operate on the present ventilation state for about 30 minutes and then shut down. The air conditioner can be operated using the unit's own remote control.</p> <p>The central apartment unit and its components resume normal control operation as soon as power returns.</p>
Error messages	<p>The QAX913 delivers detailed error messages to simplify localizing any errors. They are output as clear-text messages, thus simplifying the interpretation of messages by the user or the heating engineer.</p> <p>Error messages can be used for triggering other events, such as optical or audible alarms.</p> <p>The last 10 error messages are saved in history and can be individually retrieved.</p>
Supply state	<p>The central apartment unit can be reset to the supply state via an operating line.</p>

Application examples

1 room group with room control and hot water handling without precontroller

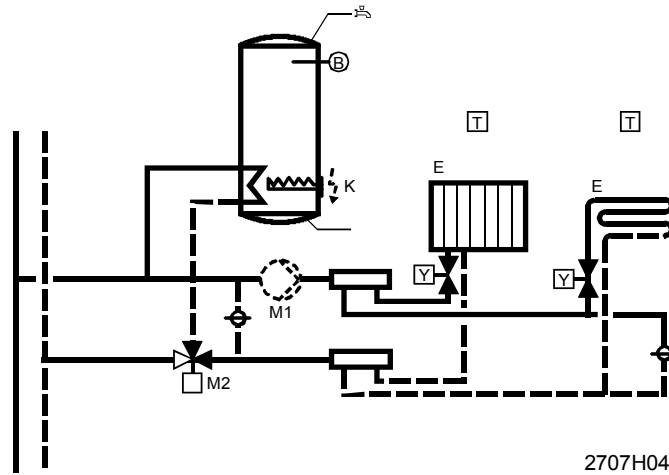

M1	Room group pump	Y	Heating circuit valve (2-point) or Radiator – control actuator SSA955
M2	Hot water diverting valve	B	DHW sensor
E	Heating circuit.	K	Electrical immersion heater
T	Room unit and / or Room temperature sensor		

2 room groups with one flow temperature pre-controller each and one hot water handling

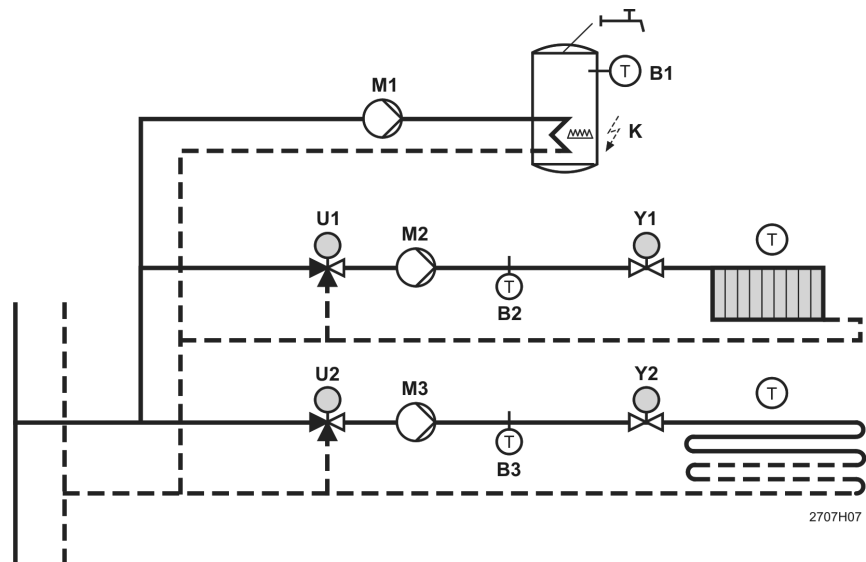

M1	DHW pump	Y1	Radiator – control actuator SSA955
M2 - M3	Room group pump	Y2	Heating circuit valve (2-point)
T	Room unit and / or Room temperature sensor	B1	DHW sensor
K	Electrical immersion heater	B2 - B3	Flow sensor
		U1	Mixing valve radiator, DC 0...10 V
		U2	Mixing valve floor heating, DC 0...10 V

Ventilation plant integration

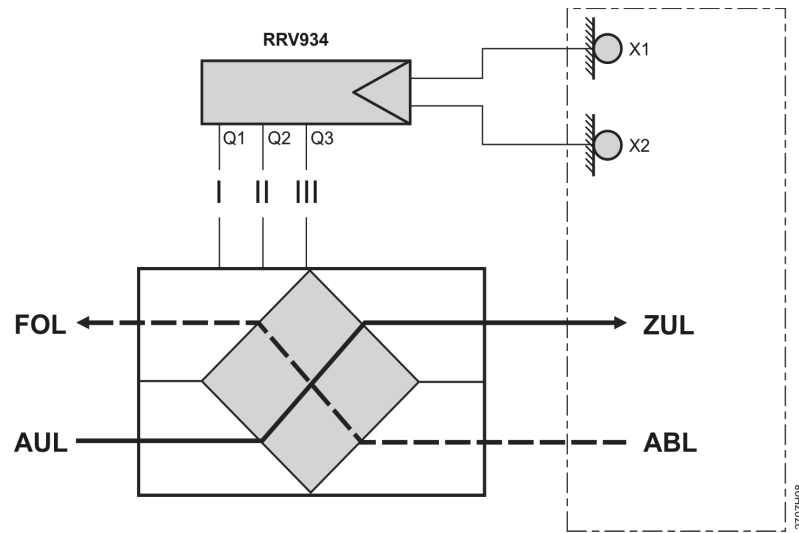

Q1 - Q3	3-stage step selector of ventilation plant	FOL	Exhaust air
X1	Air quality sensor, DC 0...10 V	AUL	Outside air
X2	Humidity sensor DC 0...10 V	ZUL	Supply air
		ABL	Extract air

Operating and display elements

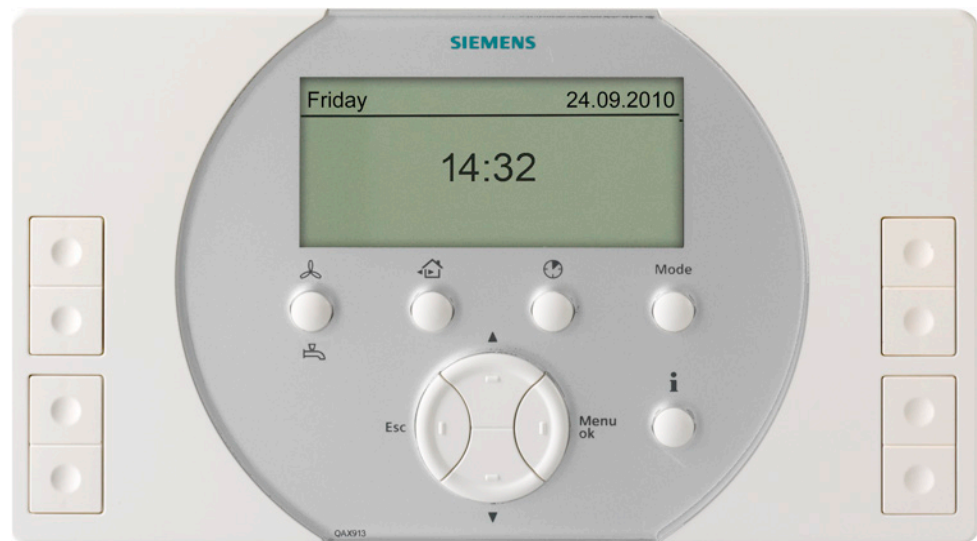

2740p03.tif

Operating element functions



Ventilation button / hot water button

Button with double occupancy for ventilation and hot water operation. Sets ventilation state (Auto / Off / Stage 1 / Stage 2 / Stage 3) and hot water operating mode (Auto / Normal / Reduced / Protection mode), as well as a manually trigger (press the button longer) for a one-time forced ventilation or hot water forced charging.



Absence / Monitor button

Selects monitoring function (inactive, partial monitor, everything monitored) and absence function (present / absent). The absence function impacts heating, ventilation, air conditioning, hot water (control to operating mode absent), starts the presence simulation program or triggers switching groups configured for absence.



Apartment timer button

This button is used to set and activate the timer function for selected rooms. Rooms are heated or cooled to the desired setpoint (Comfort, Precomfort or Economy) and operates ventilation to the corresponding setpoint stage while the timer function is enabled.



Mode button

This button selects the operating mode for the apartment (Auto / Comfort / Precomfort / Economy / Protection). The apartment operating mode simultaneously acts on room control and ventilation.



Info button

This button scrolls through the info pages and displays Help texts on the menu level.



Up arrow

This arrow button navigates upward on a menu level, to scroll backward on the info pages, and to set (increase) values.



Down arrow

This arrow button is used to navigate downward on the menu level, to scroll forward on the info pages, and to set (decrease) values.



Esc button

This button navigates back to the next higher menu level, to quit the main menu, or to abort entry of values.



Menu / ok button

This button enters the main menu, to navigate to a lower menu level, or to confirm entry of values.



Universal pair of buttons 1 - 4

These buttons trigger the switching group functions (e.g. for switching or dimming the lights) defined during commissioning, or to retrieve predefined info displays.

Display

- Fully graphic backlit display
- Visualization of information with symbols and clear-text output
- Info pages for:
 - Outside air temperature curve
 - Air pressure curve
 - Temperature display for up to 3 sensors
 - Windows / doors
 - Lighting state
 - Apartment
 - Ventilation
 - Room
 - Hot water
 - Consumption data
 - Business card
 - Button assignment (universal buttons)
 - Device status
 - fault status message bus
- Selectable format of quiescent picture

Notes on engineering and operation

Mounting location

- Comply with all local regulations on electrical systems
- The central apartment unit is designed for surface mounting
- Mount the QAX913 in a space that is easily accessible (e.g. in the living room or in the hall). The mounting height above the floor should be chosen such that the unit is easily accessible. The QAX913 does not house a temperature sensor. The mounting height has no impact on control performance
- The permissible environmental conditions must be observed
- Do not expose the QAX913 to dripping water

Note

For notes relating to engineering and mounting wireless devices for the Siemens Synco living system, refer to Data Sheet N2708en.

Installation

Use at least three screws to mount the QAX913 to an apartment's interior wall.

Maintenance

The QAX913 is maintenance-free.

Disposal



The devices are considered electronics devices for disposal in terms of European Directive 2012/19/EU and may not be disposed of as domestic garbage.

- Dispose of the devices through channels provided for this purpose.
- Comply with all local and currently applicable laws and regulations.

System limitations

System limitations (Bus TP)

126 Central apartment units QAX913

Limitation per central apartment units

1	Meteo sensor
12	Rooms
2	Door switches
8	Water detectors
1	Humidity sensors
1	Air quality sensors
1	Condensation monitor
4	Light actuator with status display (on KNX TP only (S-mode))
3	Radio repeater
4	Heat meters (heating, cooling or combined)
4	Hot water meters
4	Chilled water meters
3	Electricity meters
3	Gas meters
2	Other meters (e.g. oil, steam)
94	RF components (total, including central apartment unit)

Note

In addition to the units listed above, switching, dimming, and blinds actuators can be used in unlimited numbers.

Limitations per room	1	Type of room unit
	2	Room temperature sensor
	1	Heating circuit controller with a maximum of six channels*
	6	Radiator control actuators (1 master controller, 0 - 5 parallel controllers) or heating circuit controller channels
	6	Window switches
	1	Smoke detector (KNX TP / S-Mode only)



Note * Radiator control actuators and heating circuit controllers cannot be used simultaneously in the same room.

Warranty

Application-related technical data are only warranted in connection with the Siemens Synco living system.

User is responsible for proper operation of QAX913 when used together with third-party devices not specifically mentioned here. Siemens assumes no responsibility for service and warranty under these circumstances.

Technical data

Power supply	Operating voltage	AC 230 V ($\pm 10\%$)
	Frequency	50 Hz
	Power consumption (with no extern. load)	Max. 7 VA
	External supply line protection	Slow-blow fuse max. 10 A or Circuit breaker max. 13 A Characteristic B, C, D according to EN 60898
	Reserve of clock	Typically 72 hours
Radio communication	RF	868.3 MHz (bidirectional)
	Range	typically 30 m in buildings
	RF protocol	KNX RF-compatible 
Wired communications	Bus protocol / type	KNX TP 
	Bus power supply	Simplified bus power supply, 12.5 mA; bus power supply may only be switched on for operating an OZW771 or OZW772.
	Service interface	RJ45 socket on underside of housing
Display	Fully graphic backlit display (white background)	
Universal input	Type	LG-Ni1000 resistance, on / off
	Number	1
	Measuring range	0...120 °C
Permissible cable length to sensor or external switch	Copper cable 0.6 mm dia.	Max. 20 m
	Copper cable 1 mm ²	Max. 80 m
	Copper cable 1.5 mm ²	Max. 120 m
Relay output	Number	1
	Type	NO contact AC 24...230 V, AC 0.02...2 (2) A
	External supply line protection	See section power supply
Electrical connections	Screw terminals for	Max. 1.5 mm ²

Protection	Safety class	II to EN 60730		
	Degree of protection of housing	IP20 to EN 60 529		
	Degree of pollution	2 to EN 60 730		
Environmental conditions		Operation	Transport	Storage
		IEC 60721-3-3	IEC 60721-3-2	IEC 60721-3-1
	Climatic conditions	Class 3K5	Class 2K3	Class 1K3
	Temperature	0...+45 °C	-25...+70 °C	-20...+65 °C
	Humidity	< 95% r.h. (noncondensing)	<95% r.h.	< 95% r.h. (noncondensing)
	Mechanical conditions	Class 3M2	Class 2M2	Class 1M2
	Use above sea level	Min. 700 hPa, Max. 3,000 m above sea level		
Standards, directive and approvals	Product standard EN 60730-1	Automatic electrical controls for household and similar use		
	Product family standard EN 50491-x	General requirements for Home and Building Electronic Systems (HBES) and Building Automation and Control Systems (BACS)		
	Electromagnetic compatibility (Applications)	For use in residential, commerce, light-industrial and industrial environments		
	EU conformity (CE) EAC conformity	CE1T2707xx *) Eurasia conformity		
eu.bac	Meets the requirements for eu.bac certification			
	See product list at: http://www.eubaccert.org/licences-by-criteria.asp			
	QAX913-9	Energy efficiency class	Control accuracy in K	
	Water Heating System (RTp) / License 213351	AA	0.4	
	Water Floor Heating Systems / License 215477	AA	0.5	
	Environmental compatibility	Product environmental declaration (contains data on RoHS compliance, materials composition, packaging, environmental benefit, disposal)	CE1E2740 *)	
Eco design and labeling directives	Application with one outside temperature sensor and up to 12 room temperature sensors and on/off, PWM, or modulating control *)	Class VIII	Efficiency gain 5%	
Housing material	*) in combination with separate boiler controller (e.g. Synco 700) Plastic ASA+PC			
Housing color	White NCS S 0502-G			
Dimensions	Refer to "Dimensions"			
Weight	Unit complete with accessories			
	- QAX913-xx	0.857 kg		
	- QAX913-9	0.584 kg		

Connection terminals

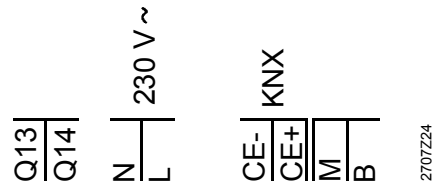

Q13, Q14	Universal, potential-free relay output
N	Operating voltage, neutral conductor AC 230 V
L	Operating voltage, live conductor AC 230 V
CE-, CE+	Connection of data bus (KNX TP- and KNX TP+)
M	Ground for universal input
B	Universal input

Connection diagram

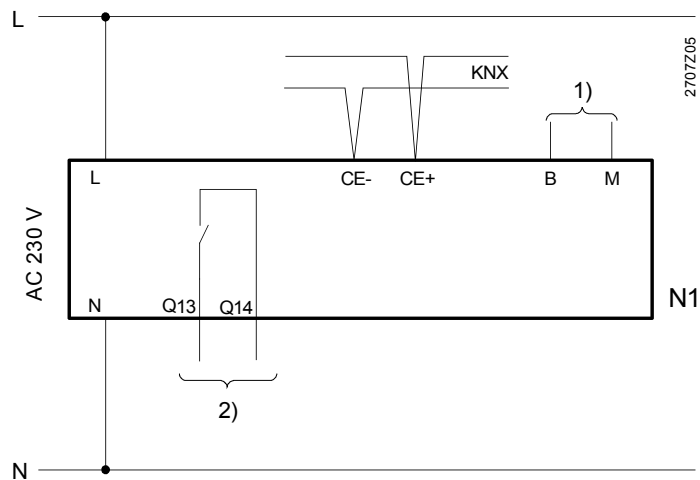

N1	Central apartment unit QAX913
1)	Universal input, for temperature measurement / digital input
2)	Universal, potential-free relay output, for mains or low-voltage
L	Live conductor AC 230 V
N	Neutral conductor AC 230 V
CE- / CE+	Connection of wire-bound bus (KNX TP- and KNX TP+)

Dimensions

Dimensions in mm

Central apartment unit

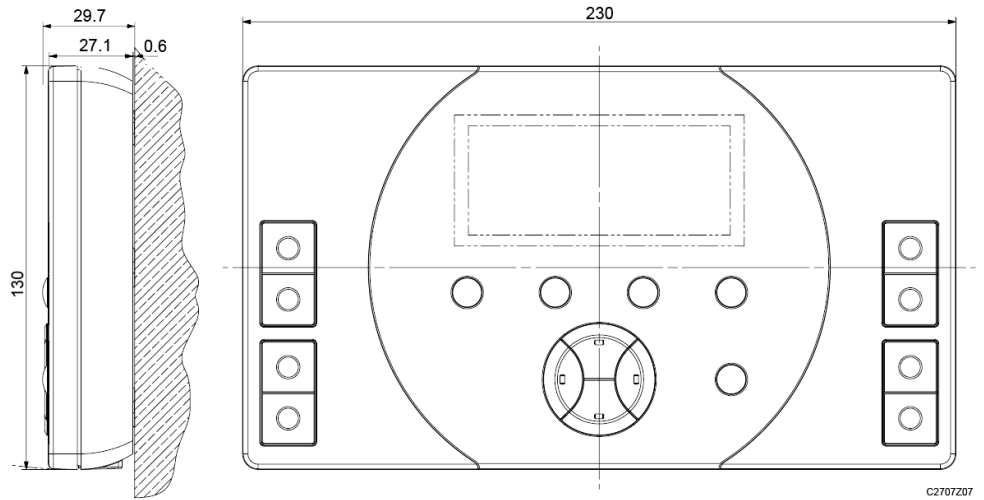

Base

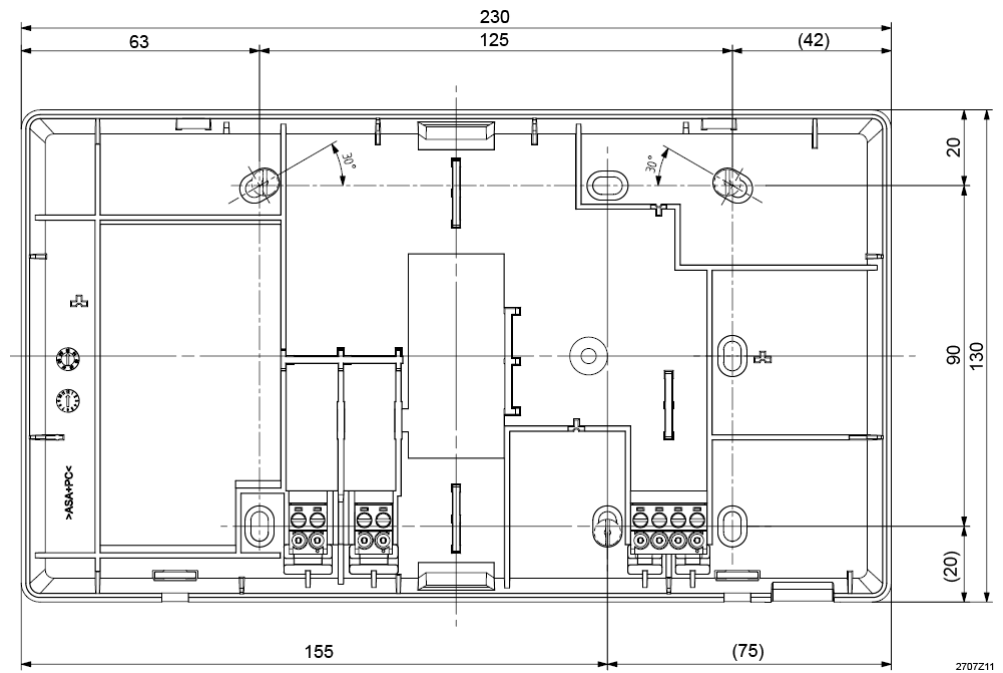

Published by:
 Siemens Switzerland Ltd.
 Building Technologies Division
 International Headquarters
 Gubelstrasse 22
 6301 Zug
 Switzerland
 Tel. +41 41-724 24 24
www.siemens.com/buildingtechnologies

© Siemens Switzerland Ltd 2010
 Delivery and technical specifications subject to change